

RECOMMENDED PCB LAYOUT
GENERAL TOLERANCE ±0.05

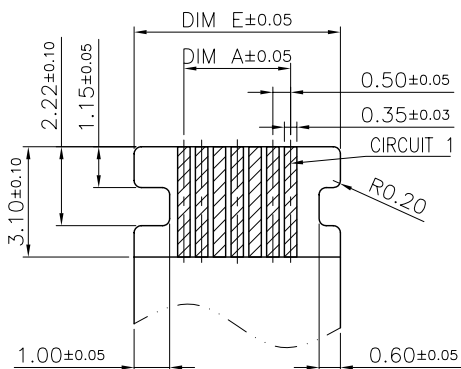

APPLICABLE FPC
RECOMMENDED DIM.
(THICKNESS: 0.3±0.03)

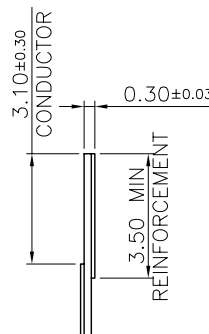

NOTES:

1. MATERIAL:

- 1.1 HOUSING: THERMOPLASTIC, HIGH TEMP.,UL94V-0; COLOR:NATURAL.
- 1.2 ACTUATOR: THERMOPLASTIC, HIGH TEMP.,UL94V-0; COLOR:BLACK.
- 1.3 CONTACT: COPPER ALLOY
- 1.4 FITTING NAIL: COPPER ALLOY

2. FINISH:

- 2.1 CONTACT:50u" MIN. NICKEL PLATING OVERALL, GOLD FLASH PLATING ON CONTACT AND SOLDER AREA;
- 2.2 FITTING NAIL:50u" MIN. NICKEL UNDERPLATING OVERALL, 80u" MIN. MATT TIN PLATING.

- 3. REFLOW SOLDER CAPABLE TO 260°C PER ACES SPEC.
- 4. SPEC. PLS. REFER TO PS-51580-XXXXX-XXX.
- 5. PACKAGE PLS. REFER TO 51699-XXXXX-XX-TRP.
- 6. PART NUMBER

51699-XXX X X-XXX

NO OF CKT

- 0: TAPE & REEL
- 4: TAPE & REEL WITH MYLAR

PLATING
1: GOLD FLASH PLATING ON CONTACT AND SOLDER AREA

	HOUSING MATERIAL&COLOR	ACTUATOR MATERIAL&COLOR	HALOGEN FREE
001	HF PLASTIC & NATURAL	HF PLASTIC & BLACK	HF

CKT	Dim A	Dim B	Dim C	Dim D	Dim E	M/s(W)
6	2.50	3.80	9.00	6.63	5.30	6.00

一般公差 TOLERANCES X ±0.50 XX ±0.15 X ±0.25 XXX ±0.10 ANGLES ±2°		宏致電子股份有限公司 Aces Electronics Co.,Ltd.	
檢驗尺寸標示 SYMBOLS ④ INDICATE CLASSIFICATION DIMENSION ④ MARK IS CRITICAL DIM. ④ MARK IS MAJOR DIM.	品名 (TITLE) 0.5 PITCH EASY ON FPC CONN H=1.3mm SMT R/A TYPE	製圖 (DR) 17/04/14 XUBIN 審核 (CHKD) BRAVE	核准 (APPD) FRANK
表面處理 (FINISH)	圖號 (DWG NO.) 51699-XXXXX-XXX	比例 (SCALE) 3:1	單位 (UNITS) mm
		張數 (SHEET) 1 OF 1	圖號 (DWG NO.) 17/04/14 XUBIN 審核 (CHKD) BRAVE 核准 (APPD) FRANK
		尺寸 (SIZE) A4	圖號 (DWG NO.) 17/04/14 XUBIN 審核 (CHKD) BRAVE 核准 (APPD) FRANK